

Relay module type CP 24

Relay Module type CP 24

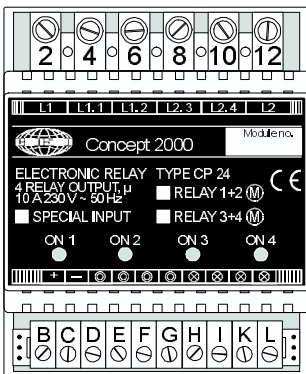

EAN-No. 5703513005207

Product description

Universal Relay module type CP 24 is a programmable relay module with 4 relay outputs (2x2) - so that two outputs have a joint 10 A input. The module has 4 direct control inputs for control of the 4 relays. Each input is attached to a relay. The inputs can be programmed separately with function for toggle switch (standard) or special functions help relay or automatic step (with different times). Furthermore a mutual blocking of 2x2 relays can be programmed for curtain or screen control with help/ toggle switch/ or toggle with time function.

The module contains in addition 4 light diodes that indicate whether relays are turned on or off. These 4 light diodes are connected with 4 indication outputs which, if necessary, can be used in connection with EDP surveillance and monitor panels. Each indication output must maximum be loaded with 75 mA.

Power supply is via the 3-pin plug provided, which is connected to the modules. Via this plug plus (24 V DC), minus and data are connected. Over the data bus Switch-Link type CP 20 or Remote-Link type CP 70 can control the relay module. At operation over the bus it is possible to programme up to 40 functions (see action overview), which the relay must carry out when a bus command is received. Programming of special functions and bus functions is carried out with the programming key CONKEY type CP 79 or via a PC.

Possible applications relay module CP 24

Lighting



Motor control



Other electric appliances



Control options relay module CP 24

General control of relay module (relay 1-4) via the data bus:

- "Sleep timer"- function (time functions)
- Light group turn on/off
- All on (preprogrammed)
- All off (preprogrammed)
- Remote control from Remote-Link type CP 70A, B, and C.
- Imitated habitation from Time-Link CP 70D
- Burglar alarm from Time-Link CP 70D
- Central control of motors (curtains, screen)
- Blocking
- And much more

Direct control inputs relay 1-4:

- 4 pcs. toggle switches (on/off) or
- 4 pcs. automatic step (time function) or
- 4 pcs. help relays
- 2 pcs. motor controls with mutual blocking of 2 relays (relay 1+2/ relay 3+4), toggle, time, and help function is applicable.

*** NOTICE! Above-mentioned functions can be combined. With motor controls for curtains, screen, or something else, you must make sure that the module is programmed with mutual blocking (relay1+2/3+4).**

Connection diagram relay module CP 24

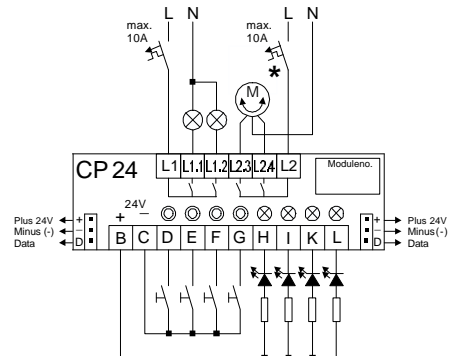

Terminals:

Mains current	Symbol	
Terminal 2	L1	Phase input relay1+2
Terminal 4	L1.1	Output relay 1 (L1)
Terminal 6	L1.2	Output relay 2 (L1)
Terminal 8	L2.3	Output relay 3 (L2)
Terminal 10	L2.4	Output relay 4 (L2)
Terminal 12	L2	Phase input relay 3+4

Low current

Terminal B	+	Plus 24V DC
Terminal C	-	Minus (-)
Terminal D	⊙	Control input relay 1 (-)
Terminal E	⊙	Control input relay 2 (-)
Terminal F	⊙	Control input relay 3 (-)
Terminal G	⊙	Control input relay 4 (-)
Terminal H	⊗	Lightdiode outputR1 (-)
Terminal I	⊗	Lightdiode outputR2 (-)
Terminal K	⊗	Lightdiode outputR3 (-)
Terminal L	⊗	Lightdiode outputR4 (-)

Technical data CP 24:

Mains current

4 outputs max. 230V AC/50 Hz	
Max. load at 230V AC/50 Hz	2x2300 VA
Load ohmic - cos phi=1,0	2x2300 VA
Load inductive - cos phi=0,5	2x1150 VA
Coupling-in time max.	20 ms
Coupling-out time max.	20 ms
Delay at mutual blocking	40-50 ms
Fuses max.	2 x 10 A

Low current

Current at 18 V DC max.	115 mA
Power consumption at 18 V DC max.	2,5 VA
Indication outputs	max. 75 mA
Current all presses	0,5 mA
Impulse time all presses min.	40 ms
Cable dimension low current	e.g. 0,6 mm
Cable length pr. input	R max. 1 K-ohm



Connection 1-phased fuse

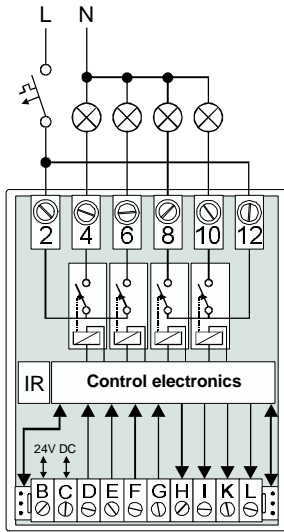

Connection 2-phased fuse

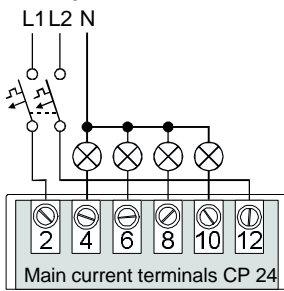

Connection 3-phased fuse

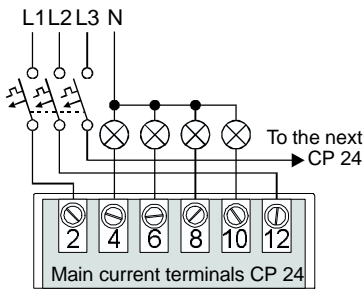

Control options of relay module type CP 24 via the data bus:

Action via CP-Bus	LCD-Conkey
Switch on	ON
Switch off	OFF
Toggle function on/off	Impulse
On for 1 second	On 1 s
On for 2 seconds	On 2 s
On for 5 seconds	On 5 s
On for 15 seconds	On 5 s
On for 30 seconds	On 30 s
On for 45 seconds	On 45 s
On for 1 minute	On 1 m
On for 5 minutes	On 5 m
On for 15 minutes	On 15 m
On for 20 minutes	On 20 m
On for 30 minutes	On 30 m
On for 45 minutes	On 45 m
On for 60 minutes	On 60 m
Off after 15 seconds	Off > 15 s
Off after 30 seconds	Off > 30 s
Off after 60 seconds	Off > 60 s
Off after 5 minutes	Off > 5 m
Off after 15 minutes	Off > 15 m
Off after 30 minutes	Off > 30 m
Off after 60 minutes	Off > 60 m
Blocking (Bus+toggle input)	Block
Help relay function *	Aux. relay

* NOTICE! Help relay function is also used at light group turn on/off. Control input on Switch-Link type CP 20, which controls light group must be programmed with Grp. turn on/off.

CP20 N2 Link No.: 1 Gp On/off: 8	CP24 N9 F8 L: SW -1 R1 A:Aux relay C:-----8
-------------------------------------	--

Preprogramming of relay module CP 24:
Relay module CP 24 is preprogrammed for "Turn off relay 1-4" at signal from Switch-Link 1-channel 1 and "Turn on relay 1-4" at signal from Switch-Link 1- channel 2. - See screen menus

CP24 N3 F1 L: SW -1 R1 A:Off C:1-----	CP24 N3 F5 L: SW -1 R1 A:On C:-2----
CP24 N3 F2 L: SW -1 R2 A:Off C:1-----	CP24 N3 F6 L: SW -1 R2 A:On C:-2----
CP24 N3 F3 L: SW -1 R3 A:Off C:1-----	CP24 N3 F7 L: SW -1 R3 A:On C:-2----
CP24 N3 F4 L: SW -1 R4 A:Off C:1-----	CP24 N3 F8 L: SW -1 R4 A:On C:-2----

Special functions relaymodule type CP 24 for direct control inputs:

Action for toggle inputs	LCD-Conkey
On for 1 second	On 1 s
On for 2 seconds	On 2 s
On for 5 seconds	On 5 s
On for 15 seconds	On 5 s
On for 30 seconds	On 30 s
On for 45 seconds	On 45 s
On for 1 minute	On 1 m
On for 5 minutes	On 5 m
On for 15 minutes	On 15 m
On for 20 minutes	On 20 m
On for 30 minutes	On 30 m
On for 45 minutes	On 45 m
On for 60 minutes	On 60 m
Help relay function	Aux relay
Mutual blocking of 2 rel.	Mut. block.

Toggle switch Automatic step Help relay

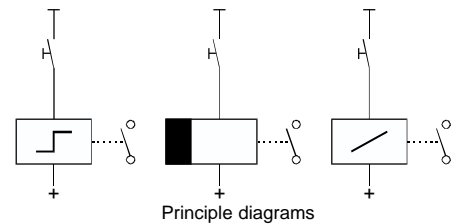

Curtain or screen controls

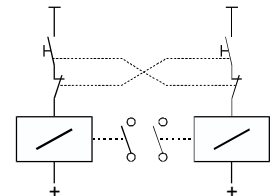

Principle diagram, relays can also be used with toggle switch, help relay, or time function at mutual blocking.

* NOTICE! At motor controls for curtains, screen or something else, you must make sure that the module is programmed with mutual blocking (relay 1+2/3+4).



Relay module type CP 24

Special functions relay module CP 24

Standard:

The 4 control inputs of the relay module for relay 1-4 is as standard preprogrammed for toggle function, i.e. you have 4 toggle switches. The programming can be changed individually pr. relay.

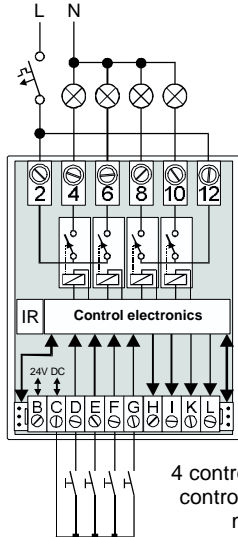

Automatic step:

The 4 direct control inputs of the relay module for relay 1-4 can separately be programmed to have an automatic step function (time function) in this way you can have up to 4 automatic steps with different times in a module CP 24.

Programming:

To be able to programme these special functions you must in the menu SET UP choose at T: (type) module type CP 24S (special functions).

```
T:CP24S N3 SF1
R1 A: -
```

By choosing CP 24S the first 4 functions (SF1 - SF4) are reserved for special functions for the 4 control inputs for relay 1-4:

- SF1 for input 1/ relay 1 (1+2 see later on)
- SF2 for input 2/ relay 2 (2+1 see later on)
- SF3 for input 3/ relay 3 (3+4 see later on)
- SF4 for input 4/ relay 4 (4+3 see later on)

At SF1 - SF4 you can choose at A: (action) a time (automatic step function), which controls the

various relays on the toggle input. The times can be different for relay 1-4 (see table of actions for toggle inputs).

Example of programming:

```
Relay 1 T:CP24S N3 SF1
R1 A: On 30 s
```

```
Relay 2 T:CP24S N3 SF2
R2 A: On 1 m
```

```
Relay 3 T:CP24S N3 SF3
R3 A: On 30 m
```

```
Relay 4 T:CP24S N3 SF4
R4 A: On 60 m
```

If you still want to use one of more relays as toggle switch and not as automatic step or something else, you abstain from setting up an action at A: (action) for SF1-SF4, relay 1-4.

Example for relay 3 - SF3 toggle switch function:

```
T:CP24S N3 SF3
R3 A: -
```

Help relay function:

The 4 control inputs can separately be used with help relay function, i.e. that relay 1-4 turn on at a constant signal (-) on input and turn off when the signal is interrupted.

Help relay function can e.g. be used when you control a dimmer module type CP 31 and at the same time want to turn on for the basic lighting with constant light level. In this case the indication output can from dimmer module type CP 31 (terminal H) be directly wired to one of the 4 control inputs on a CP 24 (terminal D, E, F, and G).

Example of programming for relay 1 and 4 - SF1 and SF4 help relay:

```
T:CP24S N3 SF1
R1 A: Aux relay
```

```
T:CP24S N3 SF4
R4 A: Aux relay
```

Motor control with mutual blocking:

The relay module CP 24 can be used for 2 motor controls UP/DOWN with mutual blocking of 2 relays. This function is used for control of e.g. curtains, screen, overhead doors and other motors, where the 2 relays for UP- and DOWN-function must have a mutual blocking.

The function ensures that the 2 relays controlling the motor never are turned on at the same time and that there is a time delay between the relays when the direction is changed (UP/DOWN) on the motor.

Mutual blocking can be chosen for relay 1+2 (motor 1) or relay 3+4 (motor 2) with functions: toggle, toggle with time and help relay function.

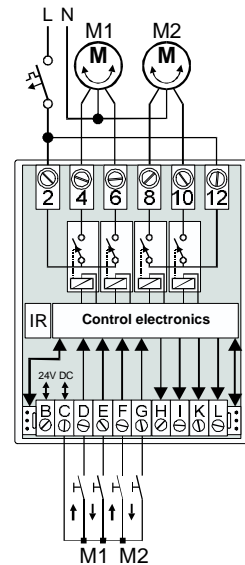

Programming of mutual blocking:

For programming of mutual blocking the following is chosen at A: (action) Mut. block..

For relay 1+2 SF1 is used and for relay 3+4 SF3.

```
T:CP24S N3 SF1
R12 A: Mut. block.
```

```
T:CP24S N3 SF3
R34 A: Mut. block.
```

At special functions SF2 and SF4 toggle, toggle with time and help relay function are chosen for relay 1+2 and relay 3+4.

See the next page >>



Relay module type CP 24

Motor control with mutual blocking:

- Continuation -

Motor control with mutual blocking and toggle function:

If you at SF1 or SF3 have chosen mutual blocking for motor control with relay 1+2 or relay 3+4 and want to operate with toggle function, you must abstain from programming an action on SF2 or SF4 at A:

The function ensures that the relays 1+2 or relay 3+4 are operated as toggle switches on/off with mutual blocking for the up/down-function (never turned on at the same time).

Example of motor control with toggle function on relay 1+2:

A short press on UP 1 button and motor 1 runs the opposite way (UP). Another press on this button and motor 1 will stop. Is the button touched again the motor will continue upwards. For DOWN 1 button it is the same (toggle function).

Is the DOWN button touched during driving up the motor will be without voltage for 40-50 ms and hereafter start driving in the opposite direction (down).

Programming of motor control with mutual blocking and toggle function:

Relay 1+2 Motorcontrol **T:CP24S N3 SF1 R12 A: Mut. block.**

Relay 1+2 Togglefunktion **T:CP24S N3 SF2 R21 A: -**

Relay 3+4 Motorcontrol **T:CP24S N3 SF3 R34 A: Mut. block.**

Relay 3+4 Togglefunktion **T:CP24S N3 SF4 R43 A: -**

Motor control with mutual blocking and toggle with time:

At SF1 or SF3 mutual blocking for motor control must be chosen with relay 1+2 or relay 3+4. If you want operation with toggle function and that the motors will be without voltage after they have made their final stop, you can programme this function on SF2 or SF4 at A:

NOTE! Toggle function with time only applies at mutual blocking and not at automatic step function.

Example on motor control with toggle with time on relay 1+2 (motor 1):

A short press on UP 1 button and motor 1 runs in one direction (UP). Another press on the button and motor 1 will stop. Is the button operated again the motor will continue upwards. After the programmed time

09.08.97

(SF2 for motor 1 and SF 3 for motor 2), where the button is not being activated, the relay turns off automatically when the time has gone. For DOWN 1 button the same function applies (toggle).

Is DOWN button operated during driving up the motor will be without voltage for 40-50 ms and hereafter start driving in the opposite direction (down).

NOTE! The time, object for programming depends on the running time of the motor from UP to DOWN and reverse.

Example of programming of motor control with mutual blocking and toggle with time:

Relay 1+2 Motorcontrol **T:CP24S N3 SF1 R12 A: Mut. block.**

Relay 1+2 toggle+time **T:CP24S N3 SF2 R21 A: On 5 m**

Relay 3+4 Motorcontrol **T:CP24S N3 SF3 R34 A: Mut. block.**

Relay 3+4 toggle+time **T:CP24S N3 SF4 R43 A: On 1 m**

Motor control with mutual blocking and help relay function:

At SF1 or SF3 mutual blocking for motor control is chosen with relay 1+2 or relay 3+4. For the help relay function is programmed on SF2 or SF4 at A: (action).

The function ensures that the relays 1+2 or relay 3+4 is operated as help relays with mutual blocking, i.e. That the motors only run as long as the buttons for UP or DOWN are activated. Relays for UP and DOWN are never turned on at the same time.

Programming of motor control with mutual blocking and help relay function:

Relay 1+2 Motorcontrol **T:CP24S N3 SF1 R12 A: Mut. block.**

Relay 1+2 helprelay **T:CP24S N3 SF2 R21 A: Aux relay**

Relay 3+4 Motorcontrol **T:CP24S N3 SF3 R34 A: Mut. block.**

Relay 3+4 helprelay **T:CP24S N3 SF4 R43 A: Aux relay**

Indication outputs

The relay module has 4 indication outputs for connection of monitor panels, control light on touch button panels or EDP/CTS-surveillance. The outputs can also be used for connection of 24V glow lamps or help relays with block diode. The indication outputs are parallel to the control lights in front of the module and must max. be loaded with 75 mA.

NOTE! Indication outputs are not short circuit protected !

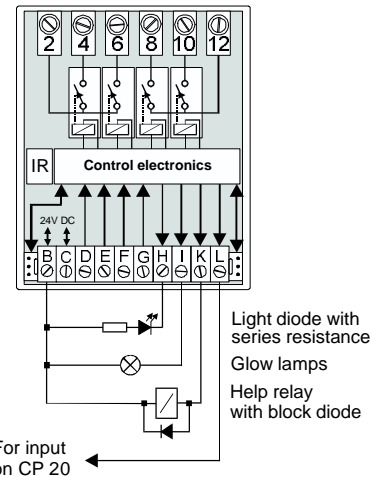

For input on CP 20

Mechanical data relay module CP 24:

Temperature range	-5°.....+35°C
Installation	for building in
Isolation	4KV > 8 mm
Insulation	DIN 40050
DIN rail symmetric	DIN 46277
Dimensions (H x W x D)	85x70x76 mm
Weight	170 g

Installation guide.

Mount module on the DIN rail and connect the plug between the modules. Via this plug +/- and "data cord" are connected. Connect mains current to the module, and check connection before voltage is supplied for the module. The module must have external power supply type CP 11(18-28V DC).

*** NOTICE! The motor controls for curtains, screen or something else, you must make sure that the module is programmed with mutual blocking (relay 1+2/3+4) before voltage is connected to the relay outputs.**



Relay module type CP 24

The use and mounting of the relay module type CP 24 (4 togglerelays) and dimmer module type Cp 31 (3 versions), controlled by the control inputs and central controlling from Switch-Link type CP 20 with the preprogrammed functions.

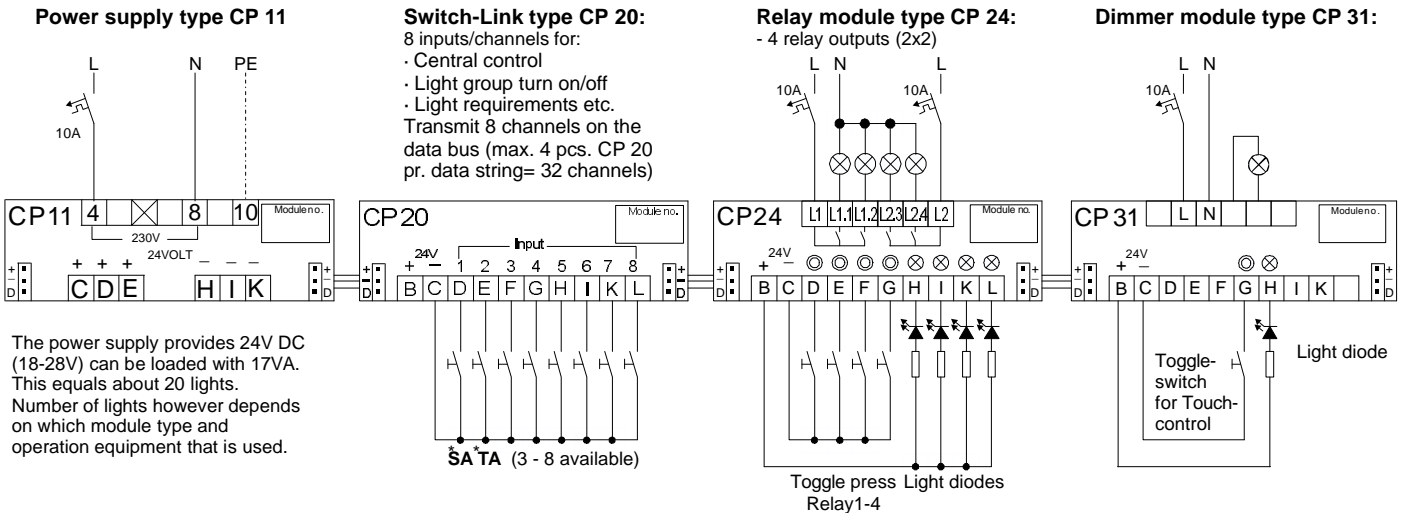

The power supply provides 24V DC (18-28V) can be loaded with 17VA. This equals about 20 lights. Number of lights however depends on which module type and operation equipment that is used.

Switch-Link type CP 20:
8 inputs/channels for:
- Central control
- Light group turn on/off
- Light requirements etc.
Transmit 8 channels on the data bus (max. 4 pcs. CP 20 pr. data string= 32 channels)

Relay module type CP 24:
- 4 relay outputs (2x2)

Dimmer module type CP 31:

* To make the forthcoming work easy, the modules preprogrammed for the following setting:

Switch-Link type CP 20 - module no. 2:
CP 20 / Link No. 1 (indicates that it is Switch-Link no. 1, max.4 pcs. pr. data string).

Relay module type CP 24 - module no. 3:
- Relay 1-4 OFF= Signal Switch-Link 1 channel 1 (CP 20 terminal D) - Function no. 1-4
- Relay 1-4 ON= Signal Switch-Link 1 channel 2 (CP 20 terminal E) - Function no. 5-8 (up to 40 functions can be programmed)

Dimmer module type CP 31LR, CP 31CR, and CP 31BC - module no. 3:
- OFF= Signal from Switch-Link 1 channel 1 (CP 20 terminal D) - Function no. 1
- ON= Signal from Switch-Link 1 channel 2 (CP 20 terminal E) - Function no. 2 (up to 40 functions can be programmed)

The above-mentioned means that you can directly connect "all off" and "all on" to Switch-Link CP 20 channel 1 and 2, and in this way have a general "all off" and "all on" function.

The screen menus below show settings which the CONCEPT 2000 modules is preprogrammed with:

Switch-Link type CP 20

T:CP20 N2 Link No.: 1
AND No. 1:

By activation of input (contact closes) the signal START is transmitted, and by deactivation (contact opens) the signal STOP on the data bus.

Function active modules:
The preprogrammed functions in active modules type CP 24 and CP 31 are activated with START-signals and make them carry out the action they are programmed with.
Type CP 24: F1 - F8
Type CP 31: F1 + F2

Relay module type CP 24

T:CP24 N3 F1 L: SW -1
R1 A:Off C:1-----

T:CP24 N3 F2 L: SW -1
R2 A:Off C:1-----

T:CP24 N3 F3 L: SW -1
R3 A:Off C:1-----

T:CP24 N3 F4 L: SW -1
R4 A:Off C:1-----

T:CP24 N3 F5 L: SW -1
R1 A:On C:2-----

T:CP24 N3 F6 L: SW -1
R2 A:On C:2-----

T:CP24 N3 F7 L: SW -1
R3 A:On C:2-----

T:CP24 N3 F8 L: SW -1
R4 A:On C:2-----

Dimmer module type CP 31

T:CP31 N3 F1 L: SW -1
R- A:Off C:1-----

T:CP31 N3 F2 L: SW -1
R- A:On C:2-----

Copy function:
After installation of the modules you must in accordance with position on switchboard write a module no. on the front label. Subsequently standard settings are read out with Conkey type CP 79 in menu GET. Afterwards the copy function is used in the Conkey. In the menu COPY settings are copied to the module no. you have given the modules (module 1,2,3,4,5 etc.) After copying, settings are adjusted in the Conkey-menu SETTING to the setting wanted and after that transmitted via the Conkey under menu SEND to the modules.



Relay module type CP 24

Example of application and programming of relay modules type CP 24 (4 relays) and Switch-Link type CP 20 for central control:

- CP 20 module no. 2: - Input 1= All off
 - Input 2= All on
 - Input 3= Light group turn on/off for CP 24 module no. relay 1 and CP 24 module no. 4 relay 2+4
- CP 24 module no. 3: - Relay 1+2 used for light control with toggle switch function (standard)
 - Relay 3+4 is used for motor control of e.g. blackout curtains
- CP 24 module no. 4: - Relay 1-4 is used for light control with toggle switch function (standard)

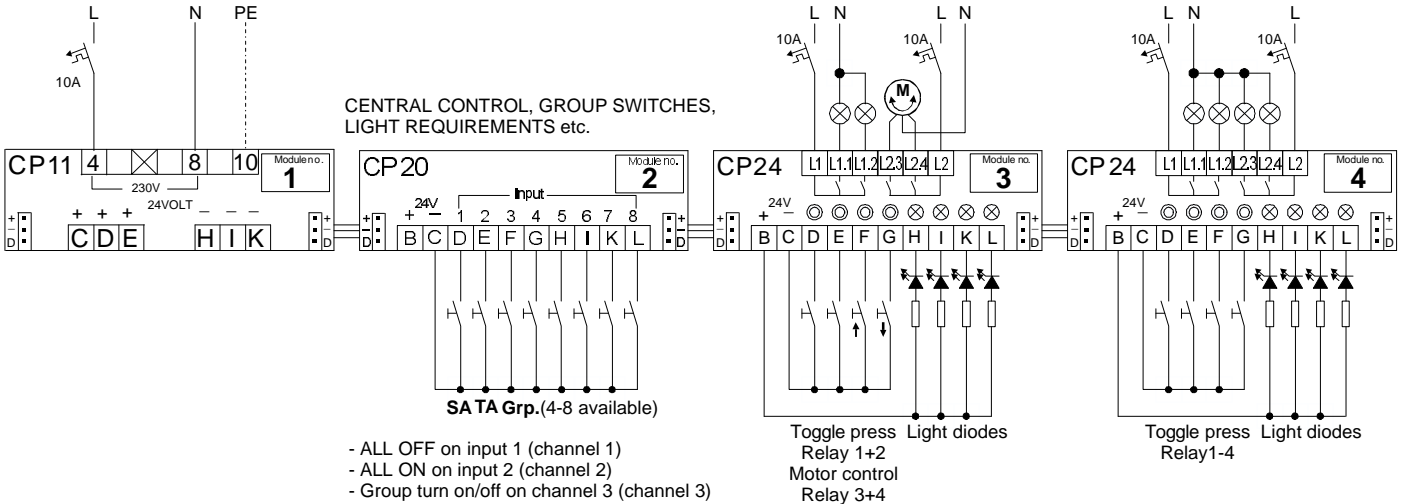

The menu pictures below show settings for the above-mentioned functions:

Switch-Link type CP 20
Module no. 2

Input/Channel no. 3
Group turn on/off

T:CP20 N2	Link No.: 1
Gp On/off: 3	

Normally an input transmits the signal START at activation (contact closes), and the signal STOP at deactivation (contact opens) on the data bus. By programming input/channel no. 3 to include group turn on/off function, signals START and STOP are alternately transmitted on the data at activations on terminal F. **Function of light group:** At START-signal the help relay turns on and at STOP-signal the help relay turns off.

Relay module type CP 24 - Module no. 3
With special functions

SF1+SF2= R 1+2 toggle switches	Function 5-8= All on R 1+2
T:CP24S N3 SF1 R1 A: -	T:CP24 N3 F7 L: SW -1 R1 A:On C:-2-----
T:CP24S N3 SF2 R2 A: -	T:CP24 N3 F8 L: SW -1 R2 A:On C:-2-----
SF3+SF4= R 3+4 Motor control	Function = Group turn on/off R 1
T:CP24S N3 SF3 R34 A: Mut. block.	T:CP24 N3 F9 L: SW -1 R1 A:Aux relay C:-3-----
T:CP24S N3 SF4 R43 A: On 5m	
Function 5-6= All off R 1+2	
T:CP24 N3 F5 L: SW -1 R1 A:Off C:1-----	
T:CP24 N3 F6 L: SW -1 R2 A:Off C:1-----	

Relay module type CP 24 - Module no. 4
Function 1-8 standard setting

Function 1-4 All off	Function 5-8 All on
T:CP24 N4 F1 L: SW -1 R1 A:Off C:1-----	T:CP24 N4 F5 L: SW -1 R1 A:On C:-2-----
T:CP24 N4 F2 L: SW -1 R2 A:Off C:1-----	T:CP24 N4 F6 L: SW -1 R2 A:On C:-2-----
T:CP24 N4 F3 L: SW -1 R3 A:Off C:1-----	T:CP24 N4 F7 L: SW -1 R3 A:On C:-2-----
T:CP24 N4 F4 L: SW -1 R4 A:Off C:1-----	T:CP24 N4 F8 L: SW -1 R4 A:On C:-2-----
	Function 9 +10 is added for group turn on/off relay 2+4
	T:CP24 N4 F9 L: SW -1 R2 A:Aux relay C:-3-----
	T:CP24 N4 F9 L: SW -1 R4 A:Aux relay C:-3-----

