

Power supply type CP 11

Power supply type CP 11

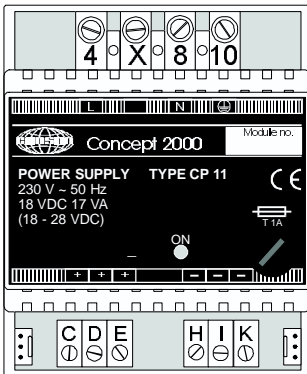

EAN-No. 5703513004231

Product description

Power supply type CP 11 is a 24 volt DC power supply for the CONCEPT 2000 system. The unit can supply 17 VA at 18 volts DC and can therefore provide for control of up to 20 lamps, curtains etc. The number of modules is, however, dependent on which modules are connected, and on whether button switches with indicator or monitor panels are also connected to the power supply. Power supply is provided via the 3-pin plug, which is connected to the modules. Plus (24 V DC), minus and data are connected via this plug. When using several power supplies, minus and data, but not plus, must be connected together on the various power supply units, i.e. you remove plus from the enclosed short bus lead or the 25 cm long bus extension cord type CP 09. The module is equipped with (+) Plus- and (-) minus terminals for connection of operation equipment. Generally, all modules in CONCEPT 2000 are not equipped with a terminal for data communication, therefore it is important to use bus extension lead type CP 09 for horizontal/vertical connection of the modules.

Reliability

By using several power supplies a good reliability is obtainable. The power supply type CP 11 is built up of a traditional iron core transformer with subsequently double rectification and smoothing condenser. The secondary voltage varies with the load and must be between 18 and 28V DC. The module is marked 18V DC equal to maximum load (17VA).

NOTE! When using several power supplies connect only minus (-) and data lead, plus is cut (see the moduleboard installation).

Moduleboard arrangement

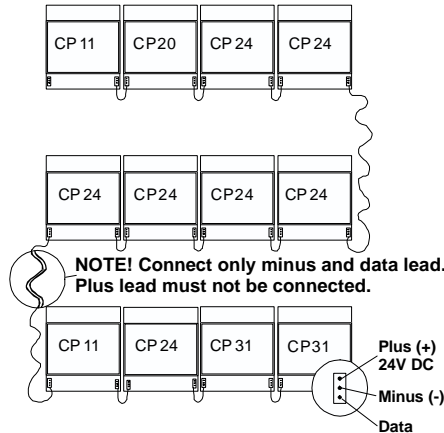

Dimensioning of power supply

At many lights, curtains etc. with e.g. relay module type CP 24 several power supplies type CP 11 are used. Type CP 11 can supply control voltage for about 20 lights, curtains etc., but it is also important to include light sensor, PIR-detectors, guiding light or control light. Especially, if glow lamps are used instead of light diode, it can have an essential impact on the load. Remember if necessary simultaneity factor, especially when you use "SESAM" button switch panel, because it **only** uses the high effect when activated.

Load guiding light/control light:
1 stk. 24V glow lamp 1,0 VA
1 stk. 24V light diode 0,1 VA

Calculation example 1:
2 pcs. CP 20 Switch-Link á 0,5VA 1,0 VA
7 pcs. CP 24 Relay module á 2,5VA 17,5 VA
3 pcs. CP 31 Dimmer á 0,5VA 1,5 VA
10pcs. LED guiding light á 0,1VA 1,0 VA
Load in total = 21,0 VA

Number CP 11= 21,0 : 17VA = 1,24 ~ 2 pcs CP11

Calculation example 2:
2 pcs. CP 20 Switch-Link á 0,5VA 1,0 VA
8 pcs. CP 24 Relay module á 2,5VA 20,0 VA
5 pcs. CP 31 Dimmer á 0,5VA 2,5 VA
1 pce. CP 70D Time-Link á 0,5VA 0,5 VA
2 pcs. CP 70B BO-Link á 1,0VA 2,0 VA
2 pcs. CP2509 IR-eye á 0,2VA 0,4 VA
15 pcs. CP2506 SESAM á 0,6VA 9,0 VA
15 pcs. LED guiding light á 0,1VA 1,5 VA
Load in total = 36,9 VA

Number CP 11= 36,9 : 17VA = 2,17 ~ 3 pcs CP11

Connection diagram power supply CP 11

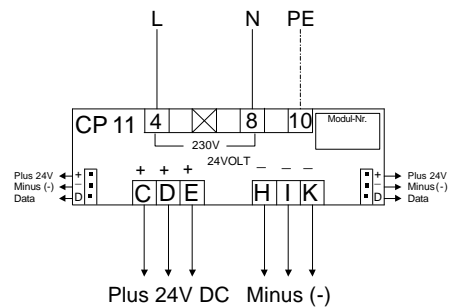

Terminals CP 11

Terminal	Symbol	Input
Terminal 4	L	Phase 220-250V~ 50Hz
Terminal 6	-	Not used
Terminal 8	N	Zero 230V AC
Terminal 10	⊕	Protective conductor

Low current

Terminal C	+	Plus 24V DC (+)
Terminal D	+	Plus 24V DC (+)
Terminal E	+	Plus 24V DC (+)
Terminal H	-	Minus (-)
Terminal I	-	Minus (-)
Terminal K	-	Minus (-)

Technical data CP 11:

Mains current	
Voltage	220-250V~ 50 Hz
Current drawn	100mA
Low current	
Voltage	24V DC (18-28V)
Current at 18 V DC max.	95 mA
Power consumption at 18 V DC max.	17 VA
Terminals for max.	2,5mm Ø

Mechanical data for CP 11

Temperature range	-5°.....+35°C
Installation	for building in
Isolation	4KV > 8 mm
Insulation	DIN 40050
DIN rail symmetric	DIN 46277
Dimensions (H x W x D)	85x70x81
Weight CP 11	610 g

Installation guide.

Mount the module on the DIN rail and connect the plug between the modules. Via this plug +/- and "data lead" are connected. Connect mains current to the module, and check connection before vol-



Power supply type CP 11/ Bus extension cord type CP 09

Joint potential

FIG. 1: At large installations it often happens that there are several individual component groups with their own power supply, e.g. when CONCEPT 2000 is combined with our large light dimmer. Figure 1 to the right shows a simplified example on two individual groups. All Conson modules inputs are activated with a "minus"(-). The figure shows how an input is connected to minus via a push-button switch. By using the minus terminal on the module involved, the optimum installation is obtained, which is very immune to electric interference fields.

FIG. 1

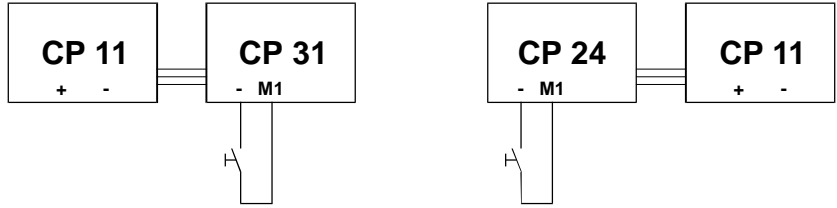

FIG. 2: Of different reasons concerning the installation, it might in some cases be easier to use a minus from another system. Figure 2 to the right shows an example where an attempt is made to get minus from another group. Unfortunately this is **not practicable**, as the two groups do not have joint potential.

FIG. 2

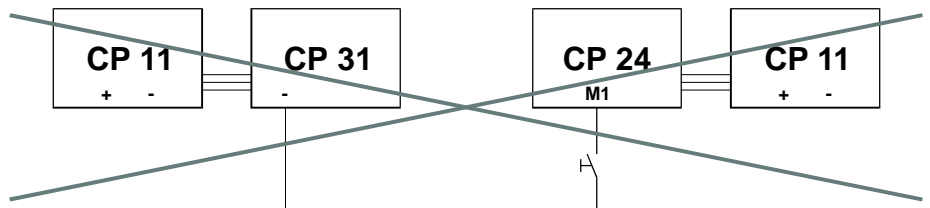
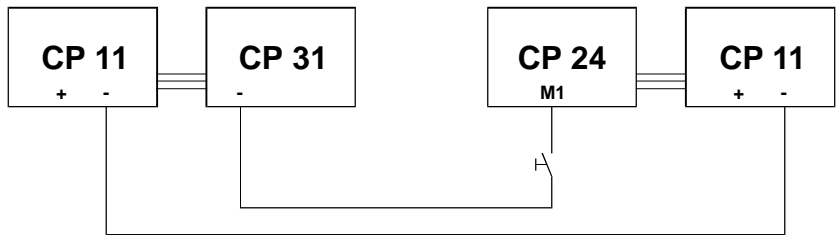

FIG. 3: However the problem can always be solved by securing a joint potential. This is done as shown in figure 3 by connecting minus on the two groups, e.g. with a lead between the minus terminals on the two power supplies.

FIG. 3



NOTE! - Missing joint potential is the most common error in low current installations.

25cm Bus extension cord type CP 09

Accessories:

25 cm bus extension cord type CP 09 for connection of two CONCEPT 2000 modules. The cord contains plus, minus and data lead, and is applicable for horizontal and vertical connection.

EAN-NO. 5703513004101

NOTE! All CONCEPT 2000 modules is delivered as standard with 1 pcs. Bus cord on 3cm, except power supply type CP 11.

